

HowTO install this

FH-CeilingMountTrack or TopMountTrack

Bypass Door System

Before you start:

READ this
HowTO (Installation
Instructions)
CAREFULLY!

(It could save you
lots of work!)

Check out the full range of products at:
www.cavitysliders.com

Keep this HowTO handy.
You may need it later on.

Another quality product from:

 CavitySliders
Quality Sliding Door Hardware

INSTALLATION NOTES

Construction of the lintel.

Construction of the lintel should be in accordance with local building regulations.

Contamination of the top track.

Never drill, nail or screw through the center section of the track **unless there are factory drilled holes for this purpose**. Make sure no dirt, grit or aluminum swarf gets into the track. This could impair the smooth running of the carriages.

TWO DOOR BYPASS SETUP

1 Level the track.

The track **must** be fitted level and straight. Screw the track to the lintel through the pre-drilled holes.

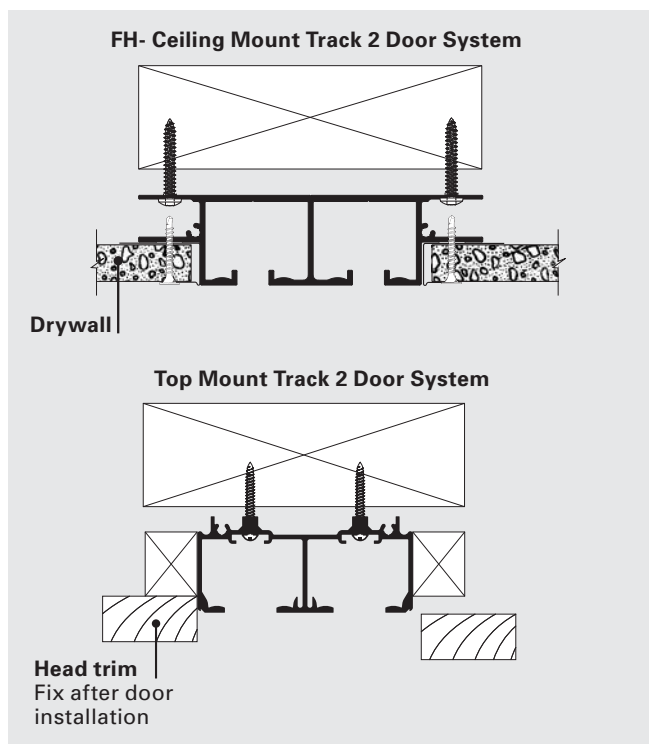

2 Fit the T-Guides.

Find the mid-point of the tracks and fit the two T-Guides. The doors should overlap by 50mm (2") when both doors are closed.

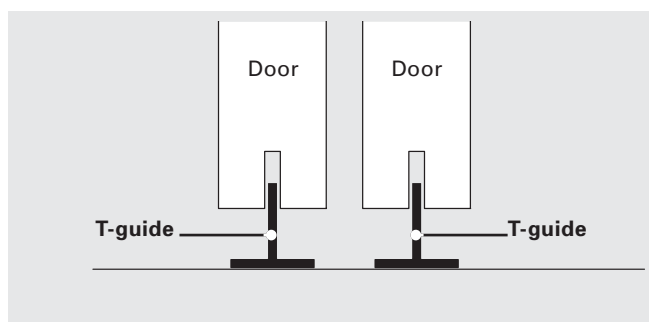

Go to page 2 (overleaf) →

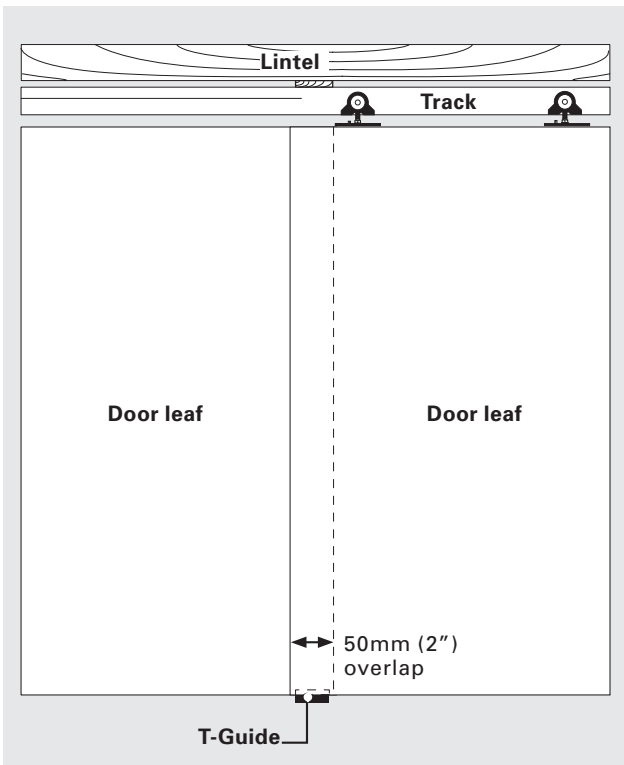

3 Prepare and fit the doors.

- At the bottom of the door leaf cut a groove to the dimension and tolerance shown. Make it central to the door thickness and absolutely straight.
- Drill mounting plate holes to the correct size and depth as marked, 85mm (3-3/8") in from the front and rear edge of your door leaf.
- Fix both mounting plates to the door. Make sure they are placed **exactly** in the center of the door thickness.

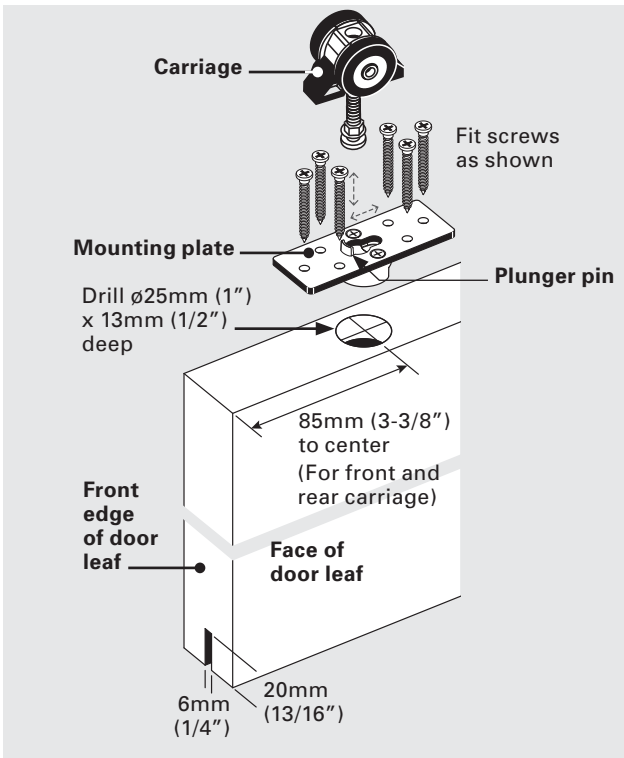

- Load the carriages into the track (two per slot) through the notched end of the track.
- Position the door underneath the set of carriages. Raise the door up so that the round head of the wheel hanger shaft lines up with the keyhole shaped hole in the mounting plate.
- Depress the plunger using the wheel hanger shaft head and slide sideways until it snaps into locked position. Repeat for the other carriages.

4 Adjusting the door heights.

Use the small end of the wrench supplied to rotate the hexagonal nut at the bottom of the carriage hanger shaft.

Adjust the doors for plumb.

To **raise** door: Rotate wrench from **left to right**.

To **lower** door: Rotate wrench from **right to left**.

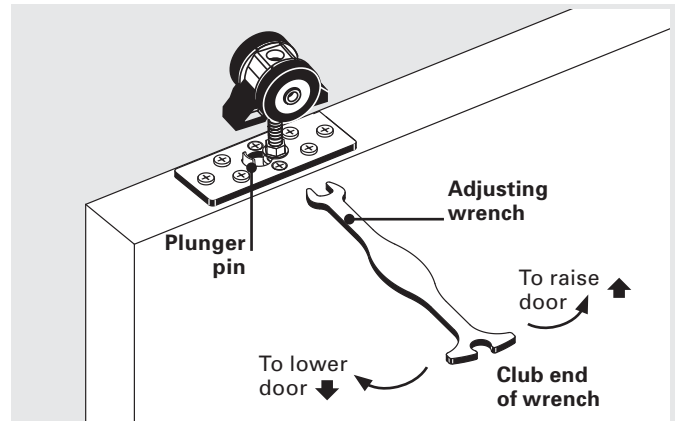

Note: The top of the hanger shaft screws into a self-locking nut. If the hexagonal nut is turned downwards too far, the shaft will become loose from the self-locking nut. If the turning resistance suddenly feels much easier, you have gone too far.

5 Removing the doors.

Fit the club end of the adjusting wrench over the hexagonal nut at the bottom of the hanger pin

Use the extended part of the wrench to press down the plunger pin that protrudes up from the mounting plate. Once this plunger is fully depressed, slide the wrench sideways towards the plunger pin.

The whole carriage (including the shaft) will now disengage from the mounting plate.

It is not always easy to slide the wrench sideways. You may need to relieve the door's weight by putting a wedge between door and floor.

Do the same with the other carriages.

If you also want to take the carriages out: slide them out from the notched end of the track.

THREE DOOR BYPASS SETUP

1 Level the track.

The track **must** be fitted level and straight. Screw the track to the lintel through the pre-drilled holes.

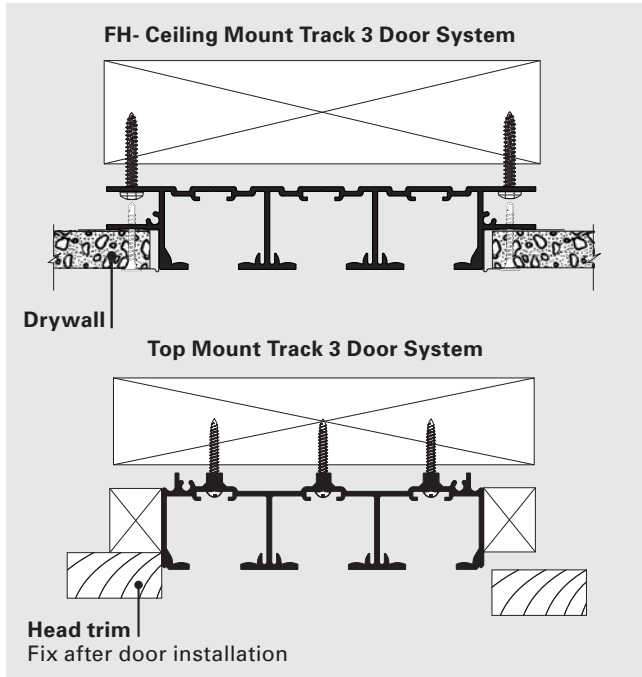

2 Fit the floor guide.

Router a groove in the floor to suit the U-Channel.

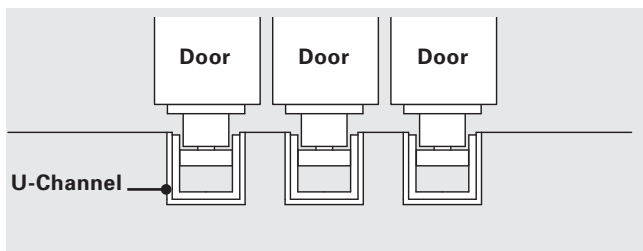

3 Prepare and fit the doors.

- Drill mounting plate holes to the correct size and depth as marked, 85mm (3-3/8") in from the front and rear edge of your door leaf.
- Fix both mounting plates to the door. Make sure they are placed **exactly** in the center of the door thickness.

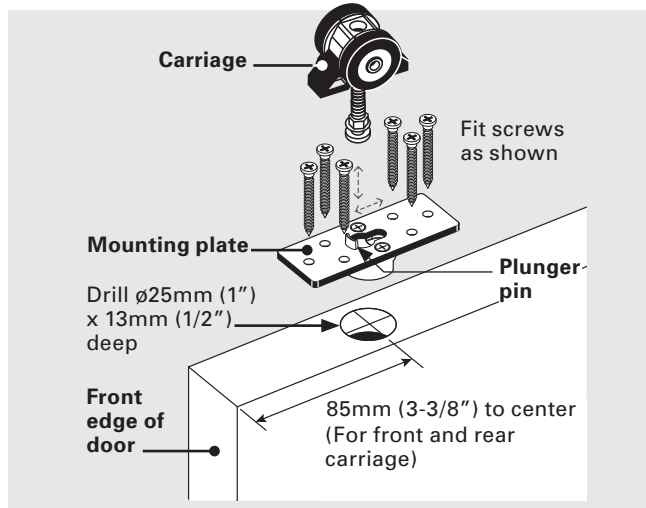

- Mount bearings at the bottom of each door using the screws supplied.

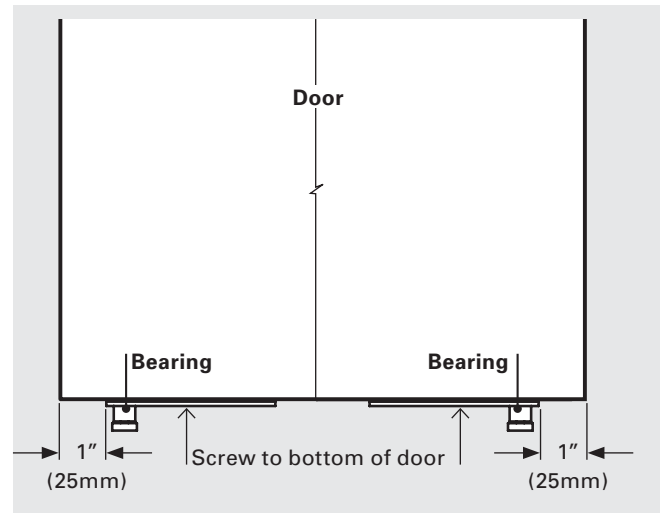

- Load the carriages into the track (two per slot) through the notched end of the track.
- Position the door underneath the set of carriages. Raise the door up so that the round head of the wheel hanger shaft lines up with the keyhole shaped hole in the mounting plate.
- Depress the plunger using the wheel hanger shaft head and slide sideways until it snaps into locked position. Repeat for the other carriages.

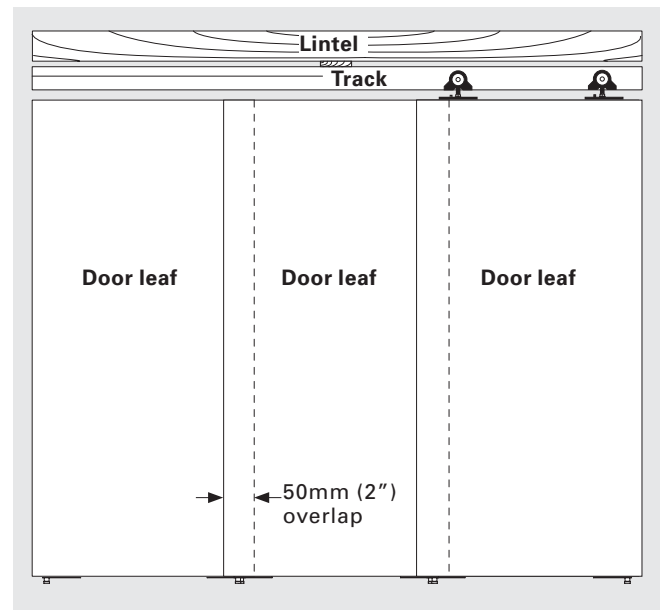

4 Adjusting or removing the doors.

Follow instructions on page 2.

CavitySliders
Quality Sliding Door Hardware

Cavity Sliders USA Inc.
548 Finney Ct
Gardena CA 90248

T (888) 466 0030
F (310) 769 5824

E info@cavitysliders.com
W www.cavitysliders.com

All copyright and other property in this document is reserved by Cavity Sliders USA Inc. Details and specifications are subject to change without notice. Whilst all care is taken to ensure the accuracy of all information, no responsibility will be accepted for any errors or omissions.

Drawings are not to scale. All dimensions are in millimeters (and inches).
© Cavity Sliders USA Inc.