

CL100 ADA IndicatorLock

Fitting Instructions

NOTE: Please read instructions before drilling any holes or marking out hole centers.

Mark both sides of the door using the template (flip template over to mark other side).

DO NOT drill right through the door as alignment issues will occur. Only drill to center.

There are five stages to fitting the Mortise Case:

- Stage 1:** Mark drilling positions for lock case.
- Stage 2:** Mark drilling positions for door furniture to be installed.
- Stage 3:** Prepare door by mortising and drilling holes.
- Stage 4:** Fit lock & door furniture.
- Stage 5:** Fit striker.

Stage 1 - Mark Drilling Positions for Lock Case

1. Mark chosen height of lock on face of door. Height is normally measured to center of square spindle (**Hole 9**).
2. Mark 'Height Line' at top of template 57.5mm (2-9/32") above **Hole 9** or 121.5mm (4-25/32") above **Hole 10** on front edge and both faces of door.

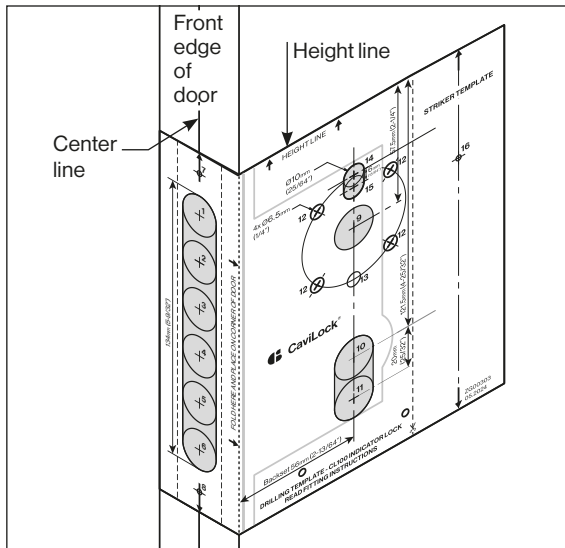

3. Make a vertical center line on front edge of door.
4. Align top edge of template with height line and arrows to vertical center line.
5. Mark universal hole positions (**Holes 1-8**) for lock case using a sharp nail or pencil.

Universal Hole Positions

Hole #	Hole Diameter	Depth		
1 - 6	19mm	3/4"	77mm	3"
7 & 8	2.5mm	3/32"	25mm	1"

Stage 2 - Mark Drilling Positions for Door Furniture

2
STAGE

1. Highlight correct drilling options required for handle and use a sharp nail or pencil to mark required hole centers. Holes 12-13 to be vertical or diagonal fixing holes at the correct hole centers to suit the lever handles being used.

Indicator Lock Hole Positions

Hole #	Hole Diameter	Depth	Door Side
9 - 11	19mm	3/4"	To Center of Door
12 or 13	6.5mm	1/4"	To Center of Door
14 & 15	10mm	25/64"	To Center of Door

Stage 3 - Mortise & Drill Holes

3
STAGE

DO NOT drill right through the door.

Alignment issues will occur. Drill to center on both sides for through holes. Check Stage 2 chart for hole depth.

1. Drill **Holes 1-6**. Make sure drilled holes are straight and level.
2. Chisel out remaining wood between holes indicated in shaded area on template to create a slot. Note: Maximum slot length not to exceed 134mm (5-9/32").
3. Drill **Holes 7 and 8**.
4. Remove face plate from lock case and temporarily screw lock case in place. Mark around outside edge of inner forend then remove lock.
5. Router out marked area to a depth of 7mm (9/32"). **Important:** Recess of front section must be routered flat and even. Long term damage will occur if not done correctly.
6. Drill **Holes 9 to 11**.
7. Remove remaining wood from oval shaped slot between **Holes 10 and 11**.
8. Drill holes for fixing handles using marks from **Stage 2**.

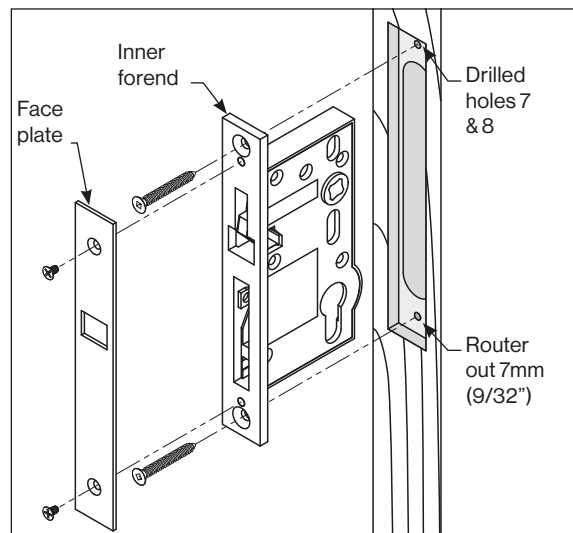

IMPORTANT: The door should be stopped in the correct closed position by the door stop, NOT the lock. If the door's momentum is not stopped by a closing jamb or an independent stop, long term damage may be done to the lock. To avoid this, ensure the door hits the jamb or stop at the same time that the striker bottoms out on the faceplate of the lock.

Stage 4 - Fit Lock and Furniture

4
STAGE

Fit lock into mortise and screw in place using #10 countersunk screws supplied.

1. Locking pin should be 0.5mm (1/64") shorter than door thickness. Cut to suit if required and de-burr the end.
2. Cut Lever & Rose handle screws to 19mm (3/4") larger than door thickness.
3. Refit faceplate.
4. Fit locking buttons with springs.
5. Check handing and hold indicator plates in place while fitting spindle and handles. Tighten screws enough to hold handles in place.
6. Test lock for the following:
 - A Handles move freely.
 - B Latch returns to the latched position when handle is let go.
 - C Locking buttons move freely without jamming.
7. Line the face plates up to be parallel to the door edge.
8. Fully tighten handles to door.
9. Drill holes for indicator plates and screw to door.

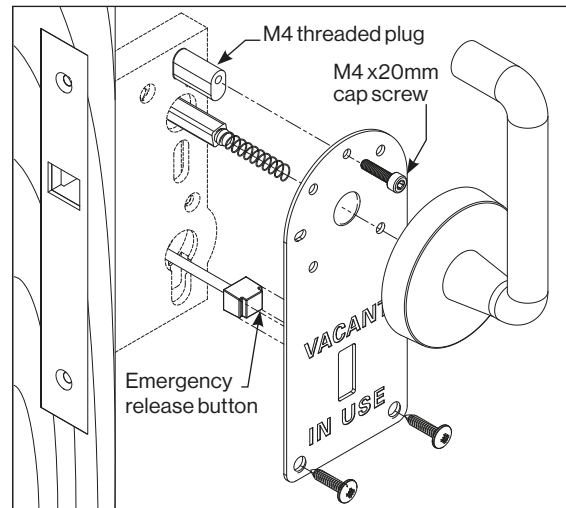

Stage 5 - Fit Striker

5
STAGE

1. Slide door closed and transfer height line from door onto closing jamb.
2. Cut out template where marked and align top of template with height line.
3. Ensure striker is facing right way up with slotted screw hole to top.
4. Mark top screw hole, ensuring it is in center of closing jamb (use center line marked on template).
5. Fit striker using top screw only. Close door slowly to check that striker lines up with lock. Adjust if necessary then fit bottom screw. On timber jambs you may mortise the back of the striker into the closing jamb to a depth of 3mm (1/8").

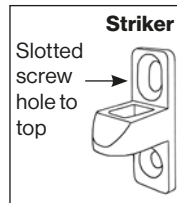

© All copyright and other property in this document is reserved by Cavity Sliders Ltd. Details and specifications are subject to change without notice. Whilst all care is taken to ensure the accuracy of all information, no responsibility will be accepted for any errors or omissions.

CAVILOCK® CL100 (O.D. 1994). ZG00302 05.2024

www.cavitysliders.com



CL100 ADA INDICATOR LOCK DRILLING TEMPLATE. Print at 100% Size

