

CAREFULLY REMOVE FROM THIS HEADER CARD

TEMPLATE

Line up with horizontal line

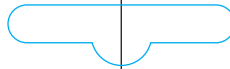

CL200

FOR DOORS
33 to 40mm THICK

CaviLock™

Handles & locks for sliding doors

PRIVACY HANDLE

for Cavity and Surface Sliding Doors

FOR DOORS GROUP
www.cavitysliders.com.au www.csforsliders.co.nz
Innovative door solutions

Type A, B or C can be re-configured on-site from the factory set manual latching to auto latching.

<input type="checkbox"/> Type 'C' Left Hand Snib Only	<input type="checkbox"/> Type 'B' Right Hand Snib Only	<input type="checkbox"/> Snib Both Sides Type 'A' Please Note: This handle can be changed to Snib / Emergency (either Left or Right hand) see instructions overleaf.
--	---	--

EASY TO FIT
INSTRUCTIONS AND
TEMPLATE ENCLOSED

Note: This handle is also available in a double door version

This Privacy Handle is suitable for residential use only
Ticked box indicates the type of Privacy Handle supplied

PREPARING THE DOOR (FOR TYPES A, B & C PRIVACY HANDLES)

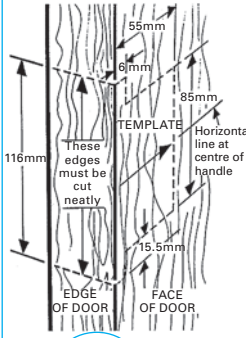

PREPARING DOOR (ALL TYPES)

1. Mark a horizontal line onto the face of the door where the centre of the handle is to fit (drawing left).
2. Position template on the door and line up the centre line of the template with the horizontal line on the door face. Draw around the template, and square the top and bottom lines across the edge of the door (shown as dotted line).

3. Cut out the door keeping to the line marked. Make sure the cut out on the edge is neat and accurate.
4. Mark the two holes for screwing the 'CaviLock' Front Plate to the edge of the door. Make sure the holes are marked exactly in the centre of the door thickness as shown (A and B)
5. Drill two x 2.5mm diameter holes to a depth of 25mm in the marked positions.

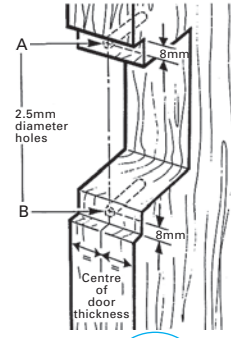

CONTINUED

OVERLEAF ▼

Never overtighten the 2 x side handle screws and 2 x CaviLock front plate screws

BEFORE YOU START: LATCHING METHOD

Manual Latching

When door is fully closed the handle is not latched until the Snib is manually pushed forward. This is how the Privacy Handle is factory set.

Auto Latching

When closing the door, the striker automatically engages the latch.

If you wish to re-configure to Auto Latching refer to section headed 'CHANGING TO AUTO LATCHING' before continuing.

SPINDLE LENGTH (see chart above right)

The square Spindle, hidden by the Snib(s) will most likely need adjusting and/or cutting to length depending on the configuration and door thickness.

SPINDLE LENGTHS (refer to example below)

DOOR THICKNESS	TYPE 'A'		TYPE 'B'	TYPE 'C'
	SNIB / SNIB	SNIB EMERGENCY	RIGHT HAND SNIB ONLY	LEFT HAND SNIB ONLY
33	Cut to 27.5mm	Cut to 18.5mm	Cut to 16.5mm	Correct length
34	Cut to 28.5mm	Cut to 19.5mm	Cut to 17.5mm	Correct length
35	Cut to 29.5mm	Cut to 20.5mm	Cut to 18.5mm	Correct length
36	Cut to 30.5mm	Cut to 21.5mm	Cut to 19.5mm	Correct length
37	Correct length	Cut to 22.5mm	Correct length	Correct length
38	Adjust 8.0mm	Cut to 23.5mm	Adjust 8.5mm	Correct length
39	Adjust 7.5mm	Cut to 24.5mm	Adjust 7.5mm	Correct length
40	Adjust 7.0mm	Cut to 25.5mm	Adjust 6.5mm	Correct length

'Adjust' means: The Spindle does not need to be cut. When fitting the first or only Snib mark the Spindle with a line (see above chart) and insert the Spindle into the Snib to this depth and tighten the Snib Grub Screw firmly.

e.g: 40mm THICK DOOR - TYPE 'A' - SNIB / SNIB = Adjust 7.0mm

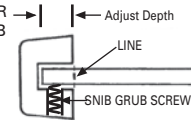

FITTING INSTRUCTIONS

1. Remove Screw Cover Plugs. Loosen Side Handle Screws to remove 'CaviLock' Front Plate.
2. Change latching method if required. Refer to 'CHANGING TO AUTO LATCHING.'
3. Compare your door thickness against the SPINDLE LENGTHS chart above. If the Spindle needs cutting down remove one Snib and then the Spindle (both the Spindle and Snibs are held in place by Grub Screws. Use 2mm Allen Key provided. See diagrams 'B' and 'C').
4. Cut the Spindle to length if necessary and deburr the cut end.
5. Refit or adjust the Snib over the CUT END of the Spindle and tighten the Grub Screw. **Don't push the Spindle right to the bottom of the square hole in the Snib on handle types marked with 'Adjust'.**
6. Line up the square hole in the latch with the slot in the Side Handle and re-insert the Spindle complete with one Snib (make sure it is the correct hand and the Grub Screw is facing the floor). DO NOT tighten the Spindle Grub Screw yet.
7. Prepare the door (Refer to PREPARING DOOR overleaf).
8. Unscrew the 2x Side Handle Screws enough to allow the handle to fit around the door

thickness.
9. Fit handle onto door (diagram A), making sure it is flush with the front of the door.

Tighten the 2x Side Handle Screws firmly to clamp the two Side Handles to the door. (Do not overtighten or fit the Screw Cover Plugs yet). Caution: If Side Handle Screws are too tight they may damage the handle and may also prevent the removal of the handle for painting of door etc.

10. Push the Snib connected to the Spindle against the flat base in the bottom of the Side Handles and then tighten the Spindle Grub Screw. Fit second Snib if required.
- NOTE: Snib on both sides - Make sure the Snibs are not pushed on too hard as this will cause the lock to jam.
- Snib on one side only - Same applies. Also check that the emergency release end of the Spindle is flush (or proud by no more than 1mm) with the flat base in the bottom of the Side Handles. Ensure all Grub Screws are firmly tightened to prevent them from loosening over time.
11. Fit 'CaviLock' Front Plate to edge of door. Screw in place using the 2 screws supplied (make sure plate is in the centre of door thickness - DO NOT OVERTIGHTEN)
12. When handle fits correctly (and door has been painted etc.), fit the two 'O' Rings to the Screw Cover Plugs and push the Plugs into the handle on each side. If 'O' Rings require lubrication we recommend Vaseline.
13. Fit the Striker as below and test.

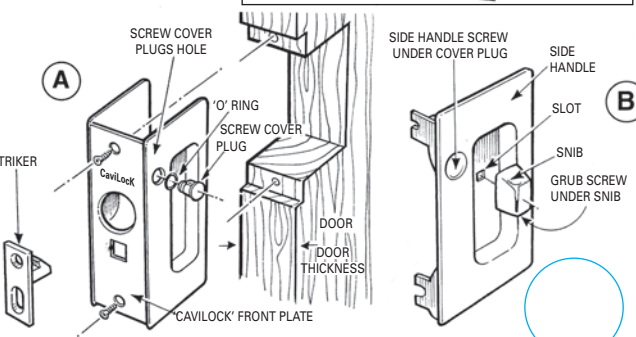

CHANGING TO AUTO LATCHING

1. Remove Screw Cover Plugs and remove both Side Handle Screws completely.
2. Remove one Snib (Held on by Grub Screw under Snib - use 2mm allen key provided in pack. See diagram 'B').
3. Remove Manual Latching Spring (already fitted) and fit Auto Latching Spring (supplied loose in pack) as per diagrams below.
- NOTE - To remove Manual Spring undo Pivot Ring Screw.
4. Continue FITTING INSTRUCTIONS at No. 3

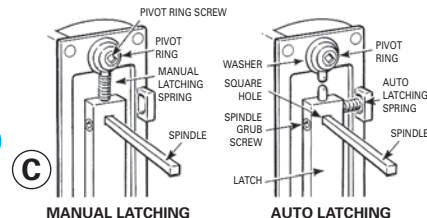

FITTING STRIKER

1. Slide door closed and transfer horizontal centre line of handle onto closing jamb. Square line across to the centre of the closing jamb as shown at right.
2. Draw vertical line in centre of closing jamb which will intercept the horizontal line as shown.
3. Measure 36mm down from the intersection point and make a mark.
4. Drill 2.5mm pilot hole and screw striker on through the bottom hole only. Slowly close the door to check that striker lines up with lock. If not, adjust striker up or down then fit second top screw. On timber jambs you may mortise the back of striker into the closing jamb to depth of 3mm.

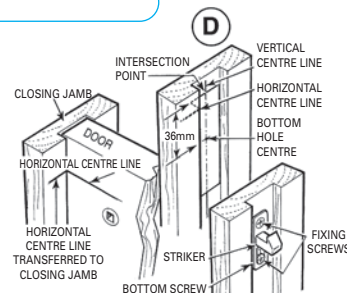

Note: This handle is also available in a double door version.